

# LSSR®/LSU

## Slopeable/Skewable Rafter Hanger



This product is preferable to similar connectors because of (a) easier installation, (b) higher loads, (c) lower installed cost, or a combination of these features.

The patent-pending LSSR slopeable/skewable rafter hanger is the next generation of field-adjustable rafter hangers. One of its key features is it can be installed after the rafter has been tacked into place. A versatile hanger, it is field adjustable for skews up to 45° and features an innovative hinged swivel seat which adjusts up to a 45° slope. New models are now available for single 2x truss members. See pp. 128–129 for more information.

### Features:

- Makes it possible to install after the rafters are already in place
- Flange design allows for easy skew (left or right) adjustment, from 0° to 45°
- Swivel seat adjusts easily from 0° to 45° up or down, and attaches to both sides of I-joist

**Material:** See tables on pp. 178–179

**Finish:** ZMAX® coating

### Installation:

- Use all specified fasteners; see General Notes
- Limit on-center spacing of rafters and joists with LSSR210-2Z and LSSR410Z to 14" o.c., minimum; for the LSSR1.81Z, LSSR2.1Z, LSSR2.37Z and LSSR2.56Z, limit the on-center spacing to 11" o.c., minimum
- For a common rafter:
  - Slide hanger into position; Adjust seat and install seat nails
  - Make sure side stirrups are snug close to the joist; bend lines are plumb
  - Install a face nail on each side to hold in place
  - Install all round and obround holes on the header and joist
- For jack rafters:
  - Fold acute side forward
  - Slide hanger into position; adjust seat and install seat nails
  - Make sure hanger is snug close to the joist; bend line is plumb
  - Install obround nails on acute side, both header and joist
  - Make sure hanger is snug close to the joist and header; bend line is plumb
  - Install joist nails on obtuse side
  - Bend obtuse side flange back so that header flange is flush against header
  - Install header nails
- Web stiffeners are required for all I-joists used with these hangers.

**Codes:** See p. 12 for Code Reference Key Chart

**Web Applications:** Visit [app.strongtie.com/hs](http://app.strongtie.com/hs) to access our Hanger Selector web application.



To watch an installation video, go to [strongtie.com/lssr](http://strongtie.com/lssr).

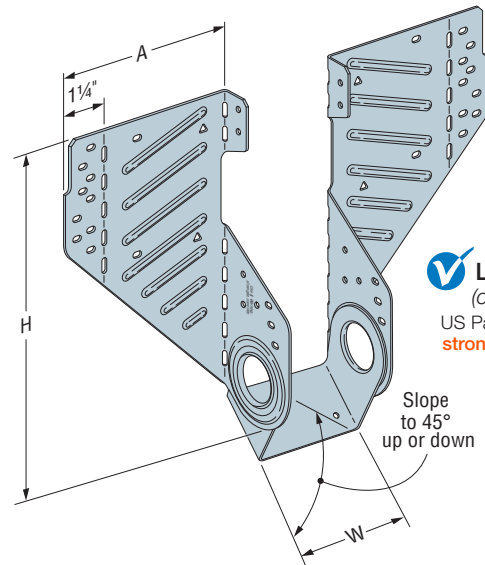

✓ **LSSR210-2**  
(others similar)  
US Patent Pending, see [strongtie.com/patents](http://strongtie.com/patents)

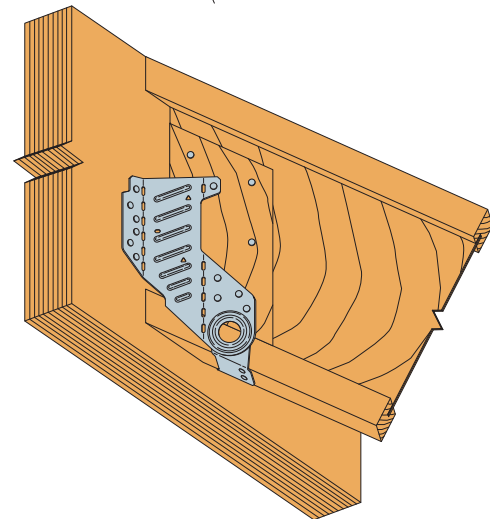

**Typical LSSR Sloped Down and Skewed Right Installation**  
(can be skewed left or right)

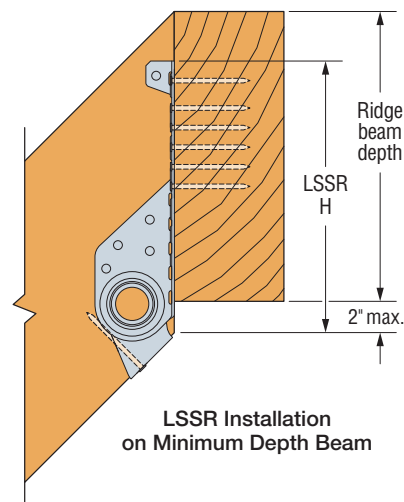

**LSSR Installation on Minimum Depth Beam**

# LSSR®/LSU

## Slopeable/Skewable Rafter Hanger (cont.)

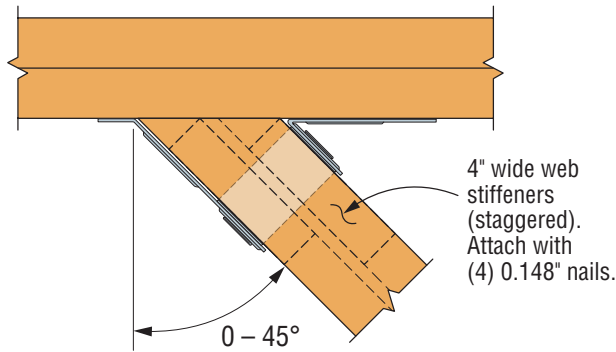

**Typical LSSR Installation**  
(compound *bevel cut*)

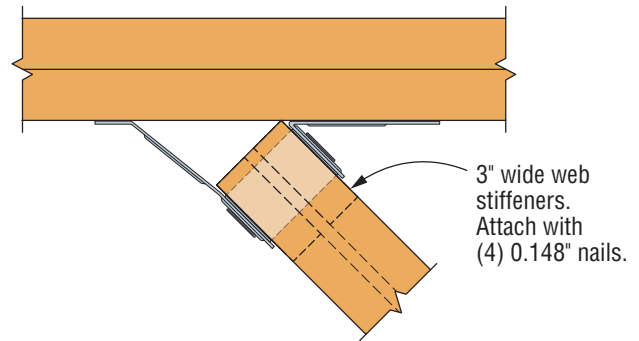

**Alternate LSSR Installation**  
(*square cut*)

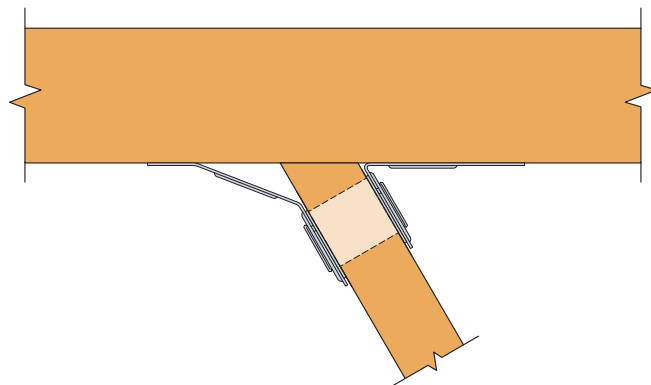

**Typical LSSR Installation**  
**Between 0° and 45° Skew**  
(compound *bevel cut*,  
*square cut similar*)

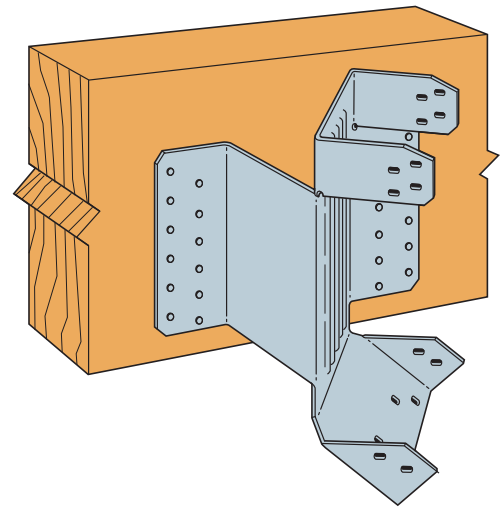

**The LSU5.12 must be factory-skewed 0° to 45°. It may be field-sloped to 45°.**  
(LSU4.12, LSU4.28 and LSU3510-2 similar)  
Hanger shown skewed right.

**LSSR®/LSU**

Slopeable/Skewable Rafter Hanger (cont.)

These products are available with additional corrosion protection. For more information, see pp. 13–19.

I-Joist, Glulam and Structural Composite Lumber Connectors

Actual Joist Width (in.)	Model No.	Ga.	Dimensions (in.)			Fasteners (in.)		Allowable Loads								Code Ref.			
			W	H	A	Face	Joist	DF/SP Species Header				SPF/HF Species Header							
								Uplift (160)	Floor (100)	Roof		Uplift (160)	Floor (100)	Roof					
				Snow (115)	Const. (125)	Snow (115)	Const. (125)												
<b>Sloped Only hanger</b>																			
1 ¼	LSSR1.81Z	18	1 13/16	8 15/16	4 1/8	(14) 0.148 x 2 1/2	(12) 0.148 x 1 1/2	510	1,565	1,565	1,565	440	1,345	1,345	1,345	IBC, FL, LA			
						(14) 0.148 x 1 1/2	(12) 0.148 x 1 1/2	510	1,175	1,175	1,175	440	1,010	1,010	1,010	—			
						(14) SD # 9 x 1 1/2	(12) SD # 9 x 1 1/2	510	1,870	1,870	1,870	440	1,610	1,610	1,610	—			
2 to 2 1/8	LSSR2.1Z					2 1/8	8 15/16	4 1/8	(14) 0.148 x 2 1/2	(12) 0.148 x 1 1/2	510	1,565	1,565	1,565	440	1,345	1,345	1,345	IBC, FL, LA
									(14) 0.148 x 1 1/2	(12) 0.148 x 1 1/2	510	1,175	1,175	1,175	440	1,010	1,010	1,010	—
									(14) SD # 9 x 1 1/2	(12) SD # 9 x 1 1/2	510	1,870	1,870	1,870	440	1,610	1,610	1,610	—
2 3/8	LSSR2.37Z		2 3/8	8 15/16	4 1/8	(14) 0.148 x 2 1/2			(12) 0.148 x 1 1/2	510	1,565	1,565	1,565	440	1,345	1,345	1,345	IBC, FL, LA	
						(14) 0.148 x 1 1/2			(12) 0.148 x 1 1/2	510	1,175	1,175	1,175	440	1,010	1,010	1,010	—	
						(14) SD # 9 x 1 1/2			(12) SD # 9 x 1 1/2	510	1,870	1,870	1,870	440	1,610	1,610	1,610	—	
2 1/2	LSSR2.56Z		2 5/8			8 15/16	4 1/8	(14) 0.148 x 2 1/2	(12) 0.148 x 1 1/2	510	1,565	1,565	1,565	440	1,345	1,345	1,345	IBC, FL, LA	
								(14) 0.148 x 1 1/2	(12) 0.148 x 1 1/2	510	1,175	1,175	1,175	440	1,010	1,010	1,010	—	
								(14) SD # 9 x 1 1/2	(12) SD # 9 x 1 1/2	510	1,870	1,870	1,870	440	1,610	1,610	1,610	—	
3	LSSR210-2Z	16	3 1/8	8 15/16	5 1/8			(22) 0.162 x 2 1/2	(18) 0.162 x 2 1/2	695	2,365	2,365	2,365	600	2,035	2,035	2,035	IBC, FL, LA	
								(22) 0.148 x 1 1/2	(18) 0.148 x 1 1/2	535	1,420	1,420	1,420	460	1,220	1,220	1,220	—	
								(22) SD #9 x 1 1/2	(18) SD #9 x 1 1/2	695	2,680	2,680	2,680	600	2,305	2,305	2,305	—	
3 1/2	LSSR410Z		3 3/8			8 15/16	5 1/8	(22) 0.162 x 2 1/2	(18) 0.162 x 2 1/2	695	2,365	2,365	2,365	600	2,035	2,035	2,035	IBC, FL, LA	
								(22) 0.148 x 1 1/2	(18) 0.148 x 1 1/2	535	1,420	1,420	1,420	460	1,220	1,220	1,220	—	
								(22) SD #9 x 1 1/2	(18) SD #9 x 1 1/2	695	2,680	2,680	2,680	600	2,305	2,305	2,305	—	
Dbl 2	LSU4.12	14	4 1/8	9	2 1/4			(24) 0.162 x 3 1/2	(16) 0.148 x 1 1/2	1,150	3,215	3,700	4,020	990	2,785	3,200	3,480	—	
Dbl 2 1/8	LSU4.28		4 1/4	9	2 3/8			(24) 0.162 x 3 1/2	(16) 0.148 x 1 1/2	1,150	3,215	3,700	4,020	990	2,785	3,200	3,480	—	
Dbl 2 3/8	LSU3510-2		4 3/4	8 7/8	3 3/8			(24) 0.162 x 3 1/2	(16) 0.148 x 1 1/2	1,150	3,215	3,700	4,020	990	2,785	3,200	3,480	—	
Dbl 2 1/2	LSU5.12		5 1/8	9	2 1/4	(24) 0.162 x 3 1/2	(16) 0.148 x 1 1/2	885	3,215	3,700	3,785	760	2,785	3,200	3,280	—			

- Uplift loads have been increased for earthquake or wind loading with no further increase allowed. Reduce where other loads govern.
- For slope-only installations, the four triangle holes may be filled for an allowable roof download of 3,015 lb. for DF/SP and 2,595 lb. for SPF/HF for LSSR 16GA. **Does not apply when 0.148" x 1 1/2" or Strong-Drive® SD screws are used in the face.**
- Roof loads are 125% of floor loads unless limited by other criteria. Floor loads may be adjusted for load durations according to the code provided they do not exceed those in the roof column.
- LSU3510-2, LSU4.12, LSU4.28, and LSU5.12 skew options must be factory-ordered.
- Minimum 11" joist height for LSU3510-2, LSU4.12, LSU5.12; 9 1/2" for all others.
- On the acute side of the skewed LSSR hanger, fill obround holes only.
- Fasteners:** Nail dimensions are listed diameter by length. **SD screws are Simpson Strong-Tie Strong-Drive SD Connector screws.** See pp. 25–26 for fastener information.

# LSSR®/LSU

## Slopeable/Skewable Rafter Hanger (cont.)

These products are available with additional corrosion protection. For more information, see pp. 13–19.

Actual Joist Width (in.)	Model No.	Ga.	Dimensions (in.)			Fasteners (in.)		Allowable Loads								Code Ref.
			W	H	A	Face	Joist	DF/SP Species Header				SPF/HF Species Header				
								Uplift (160)	Floor (100)	Roof		Uplift (160)	Floor (100)	Roof		
Skewed Hangers or Sloped and Skewed Hangers																
1 3/4	LSSR1.81Z	18	1 13/16	8 15/16	4 1/8	(14) 0.148 x 2 1/2	(12) 0.148 x 1 1/2	510	1,205	1,205	1,205	440	1,035	1,035	1,035	IBC, FL, LA
						(14) 0.148 x 1 1/2	(12) 0.148 x 1 1/2	510	905	905	905	440	775	775	775	—
						(14) SD # 9 x 1 1/2	(12) SD # 9 x 1 1/2	510	1,580	1,580	1,580	440	1,360	1,360	1,360	—
2 to 2 1/16	LSSR2.1Z	18	2 1/8	8 15/16	4 1/8	(14) 0.148 x 2 1/2	(12) 0.148 x 1 1/2	510	1,205	1,205	1,205	440	1,035	1,035	1,035	IBC, FL, LA
						(14) 0.148 x 1 1/2	(12) 0.148 x 1 1/2	510	905	905	905	440	775	775	775	—
						(14) SD # 9 x 1 1/2	(12) SD # 9 x 1 1/2	510	1,580	1,580	1,580	440	1,360	1,360	1,360	—
2 5/16	LSSR2.37Z	18	2 3/8	8 15/16	4 1/8	(14) 0.148 x 2 1/2	(12) 0.148 x 1 1/2	510	1,205	1,205	1,205	440	1,035	1,035	1,035	IBC, FL, LA
						(14) 0.148 x 1 1/2	(12) 0.148 x 1 1/2	510	905	905	905	440	775	775	775	—
						(14) SD # 9 x 1 1/2	(12) SD # 9 x 1 1/2	510	1,580	1,580	1,580	440	1,360	1,360	1,360	—
2 1/2	LSSR2.56Z	18	2 9/16	8 15/16	4 1/8	(14) 0.148 x 2 1/2	(12) 0.148 x 1 1/2	510	1,205	1,205	1,205	440	1,035	1,035	1,035	IBC, FL, LA
						(14) 0.148 x 1 1/2	(12) 0.148 x 1 1/2	510	905	905	905	440	775	775	775	—
						(14) SD # 9 x 1 1/2	(12) SD # 9 x 1 1/2	510	1,580	1,580	1,580	440	1,360	1,360	1,360	—
3	LSSR210-2Z	16	3 1/8	8 15/16	5 1/8	(22) 0.162 x 2 1/2	(18) 0.162 x 2 1/2	695	1,810	1,810	1,810	600	1,555	1,555	1,555	IBC, FL, LA
						(22) 0.148 x 1 1/2	(18) 0.148 x 1 1/2	535	1,085	1,085	1,085	460	935	935	935	—
						(22) SD #9 x 1 1/2	(18) SD #9 x 1 1/2	695	2,100	2,100	2,100	600	1,805	1,805	1,805	—
3 1/2	LSSR410Z	16	3 3/8	8 15/16	5 1/8	(22) 0.162 x 2 1/2	(18) 0.162 x 2 1/2	695	1,810	1,810	1,810	600	1,555	1,555	1,555	IBC, FL, LA
						(22) 0.148 x 1 1/2	(18) 0.148 x 1 1/2	535	1,085	1,085	1,085	460	935	935	935	—
						(22) SD #9 x 1 1/2	(18) SD #9 x 1 1/2	695	2,100	2,100	2,100	600	1,805	1,805	1,805	—
Dbl 2	LSU4.12 <sup>4</sup>	14	4 1/8	9	2 1/4	(24) 0.162 x 3 1/2	(16) 0.148 x 1 1/2	1,150	2,300	2,300	2,300	990	1,990	1,990	1,990	—
Dbl 2 1/16	LSU4.28 <sup>4</sup>		4 1/4	9	2 3/8	(24) 0.162 x 3 1/2	(16) 0.148 x 1 1/2	1,150	2,300	2,300	2,300	990	1,990	1,990	1,990	—
Dbl 2 3/16	LSU3510-2 <sup>4</sup>		4 3/4	8 7/8	3 5/8	(24) 0.162 x 3 1/2	(16) 0.148 x 1 1/2	1,150	2,300	2,300	2,300	990	1,990	1,990	1,990	—
Dbl 2 1/2	LSU5.12 <sup>4</sup>		5 1/8	9	2 1/4	(24) 0.162 x 3 1/2	(16) 0.148 x 1 1/2	885	1,790	1,790	1,790	760	1,550	1,550	1,550	—

- Uplift loads have been increased for earthquake or wind loading with no further increase allowed. Reduce where other loads govern.
- For slope-only installations, the four triangle holes may be filled for an allowable roof download of 3,015 lb. for DF/SP and 2,595 lb. for SPF/HF for LSSR 16GA. **Does not apply when 0.148" x 1 1/2" or Strong-Drive® SD screws are used in the face.**
- Roof loads are 125% of floor loads unless limited by other criteria. Floor loads may be adjusted for load durations according to the code provided they do not exceed those in the roof column.
- LSU3510-2, LSU4.12, LSU4.28, and LSU5.12 skew options must be factory-ordered.
- Minimum 11" joist height for LSU3510-2, LSU4.12, LSU5.12; 9 1/2" for all others.
- On the acute side of the skewed LSSR hanger, fill obround holes only.
- Fasteners:** Nail dimensions are listed diameter by length. **SD screws are Simpson Strong-Tie Strong-Drive SD Connector screws.** See pp. 25–26 for fastener information.

C-C-2026 © 2026 SIMPSON STRONG-TIE COMPANY, INC.

I-Joist, Glulam and Structural Composite Lumber Connectors